

# (F)(N)HDS SERIES

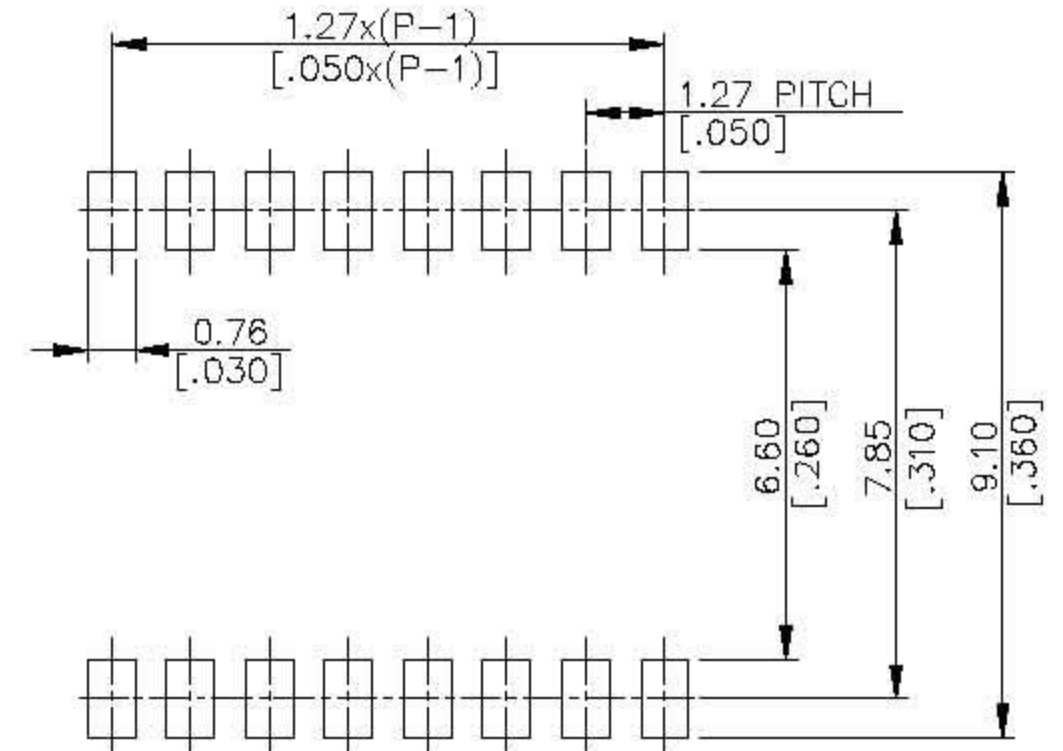

## DIMENSIONS

### FHDS (Terminal length 8.1mm)

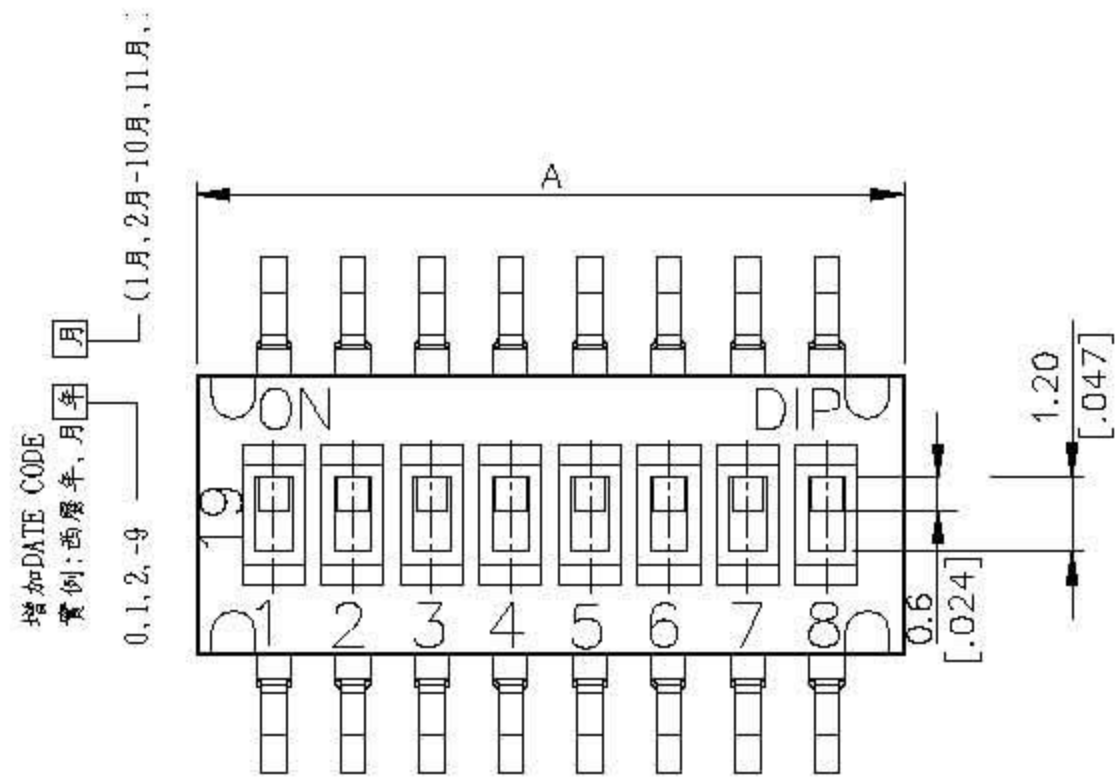
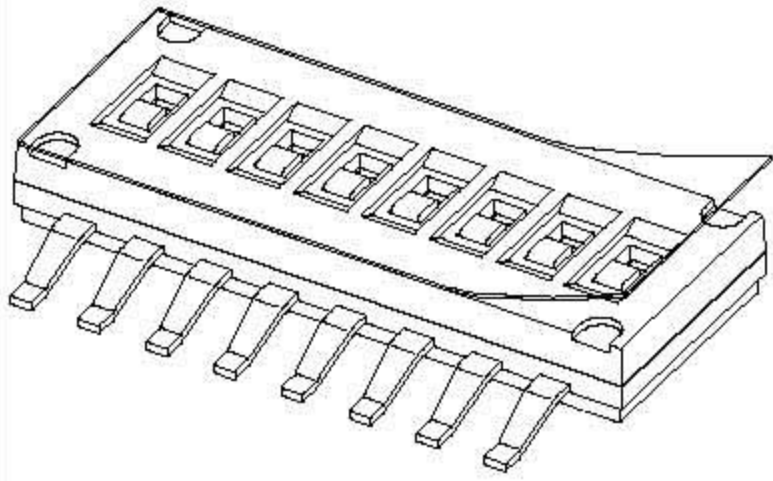

P.C.B LAYOUT

FHDS-02	2	3.77 [.148]
FHDS-04	4	6.31 [.248]
FHDS-06	6	8.85 [.348]
FHDS-08	8	11.39 [.448]
FHDS-10	10	13.93 [.548]
PROD.NO.	NO. OF POS	DIM A

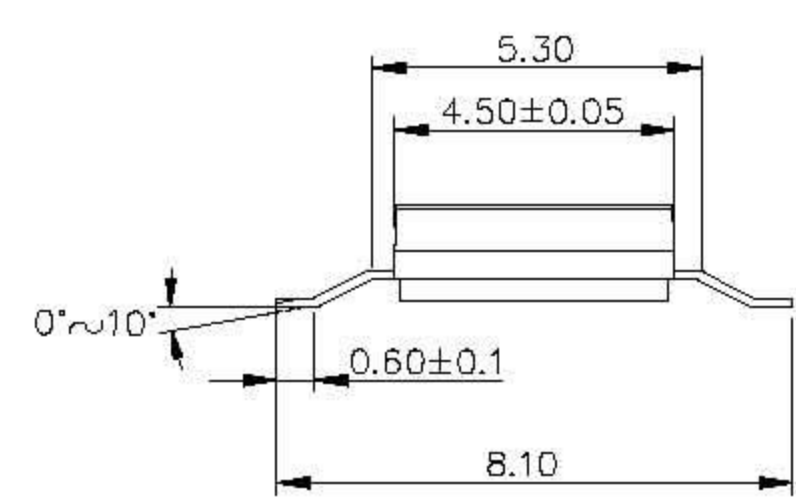
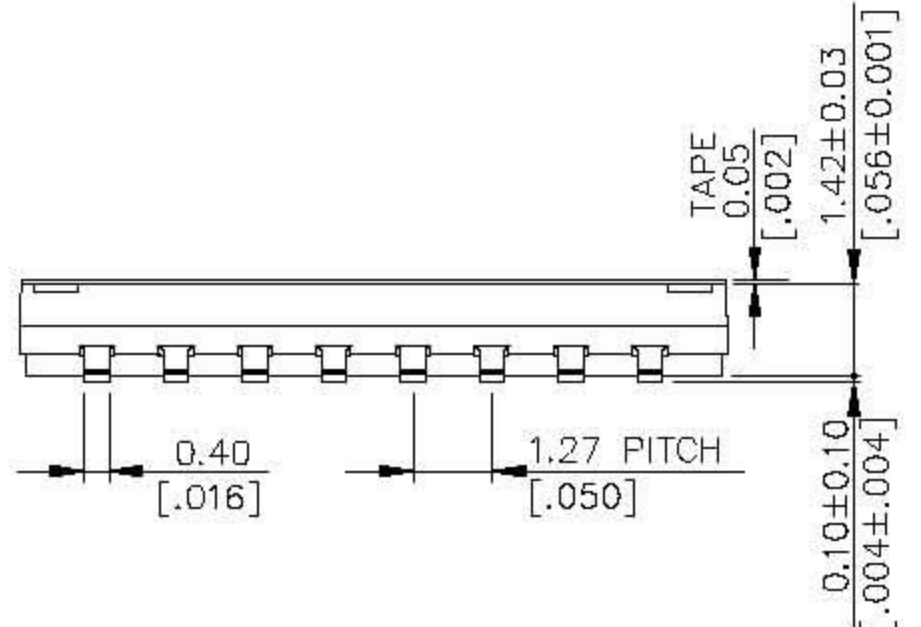

\*\*GENERAL TOLERANCES MAX ±0.2mm.\*\*

### NHDS ( Terminal length 6.7mm)

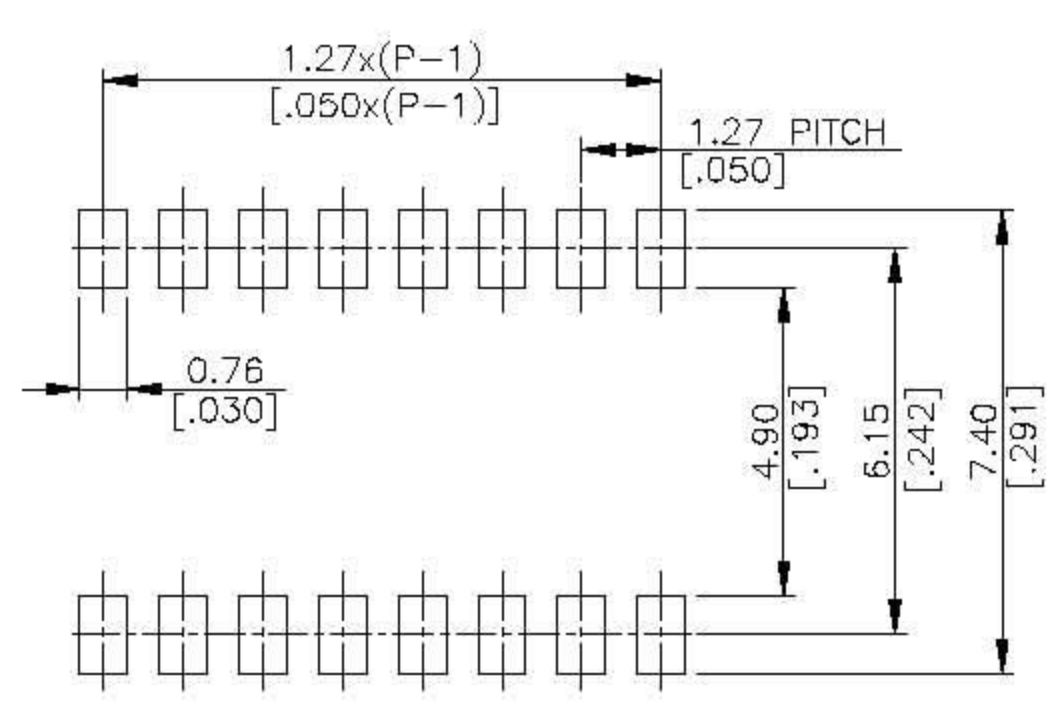
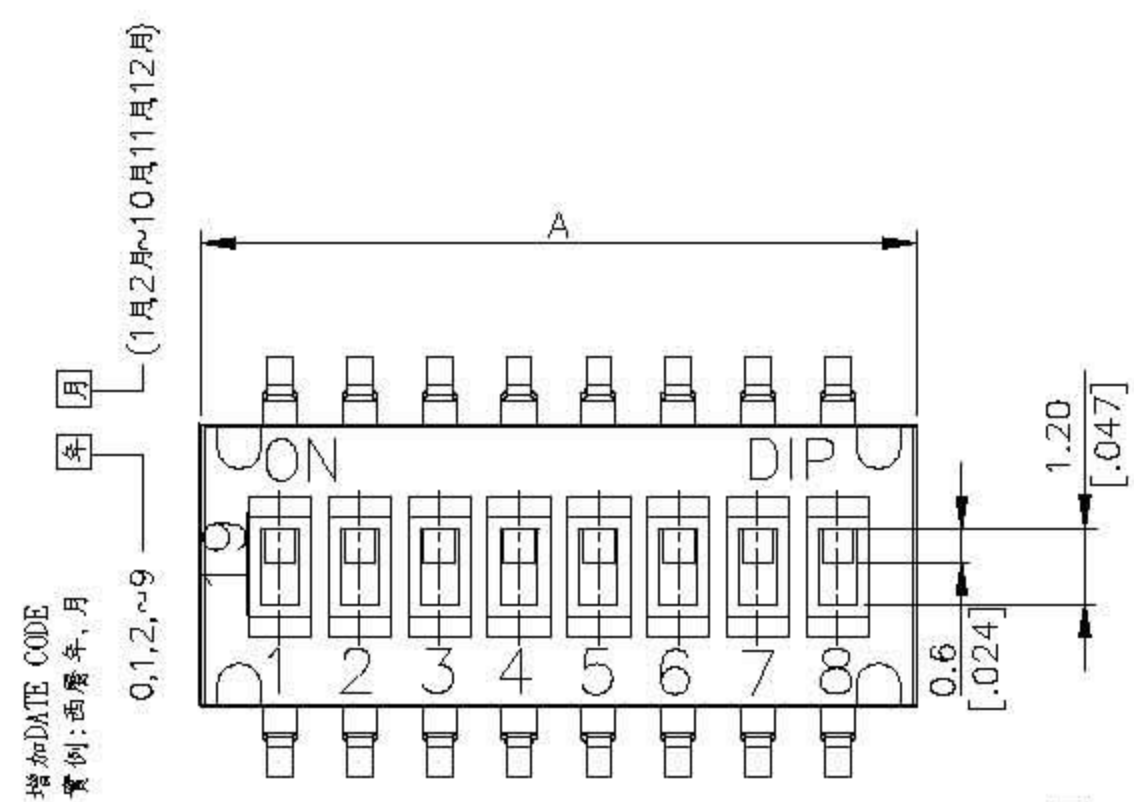
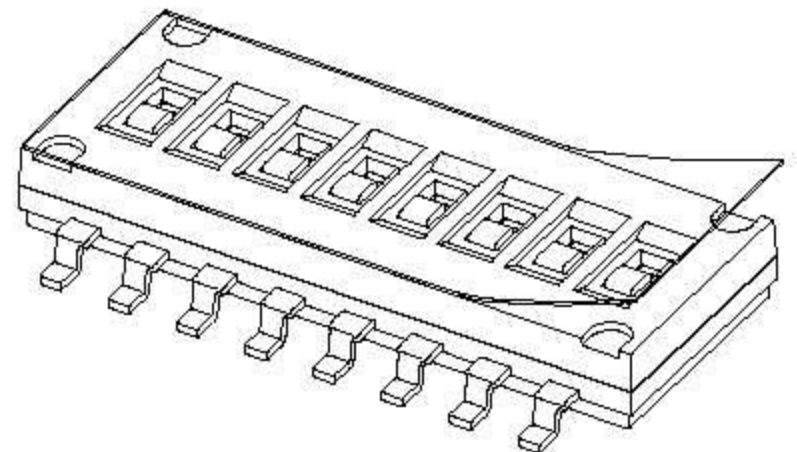

P.C.B LAYOUT

NHDS-02	2	3.77 [.148]
NHDS-04	4	6.31 [.248]
NHDS-06	6	8.85 [.348]
NHDS-08	8	11.39 [.448]
NHDS-10	10	13.93 [.548]
PROD.NO.	NO. OF POS	DIM A

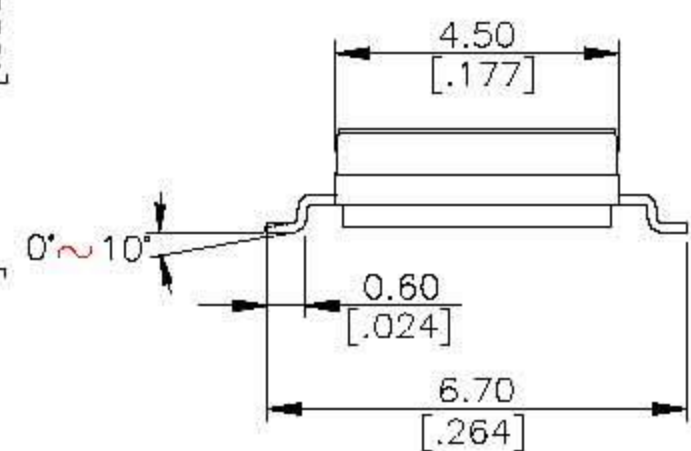
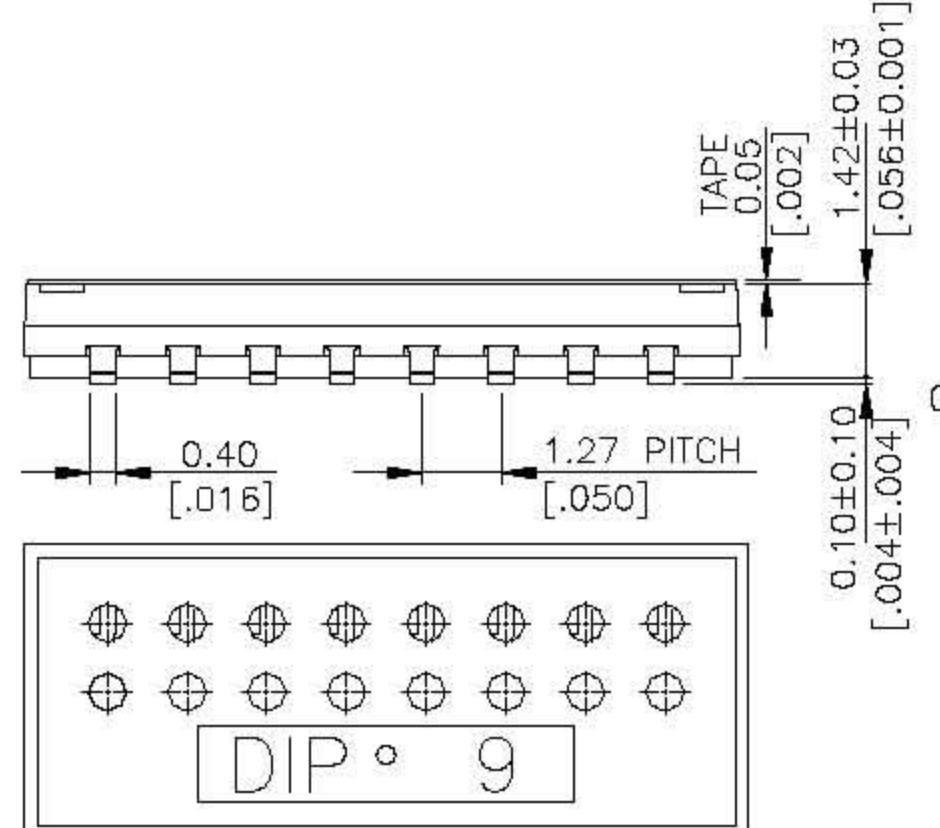

\*\*GENERAL TOLERANCES MAX ±0.2mm.\*\*

# HOW TO ORDER

(F)NHDS - □ □ □ - □ - □ - □

Package Style:

□ = Tube

T/R = Tape & Reel

Soldering

V = Lead Free Solderable

Sealed:

□ = Without Tape

T = Top Tape Sealed

F = In OFF Position

Number Of Positions:

02 = 2 Positions

04 = 4 Positions

06 = 6 Positions

08 = 8 Positions

10 = 10 Positions

F = Half Pitch Dip Switch (Terminal Length 8.1mm)

N = Half Pitch Dip Switch (Terminal Length 6.7mm)

## SPECIFICATION

Mechanical Life	Operation Force	Stroke	Operation Temperature	Storage Temperature
1000 cycles	500 gf	0.6 mm	-40°C to +85°C	-40°C to +85°C

## ELECTRICAL

Electrical Life	Non-Switching Rating	Switching Rating	Contact Resistance	Insulation Resistance	Dielectric Strength	Circuit
1000 Cycles	100 mA, 50VDC	25mA, 24VDC	100mΩ max. at initial	100MΩ min. (at 500VDC)	300VAC/1minute	SPST

## MATERIAL

△ Base	: UL 94V-0 Nylon Thermoplastic
Color	: Black
△ Cover	: UL 94V-0 Nylon Thermoplastic
Color	: Black
△ Actuators	: LCP Thermoplastic
Color	: White
△ Contact	: Alloy Copper With Gold Plated
△ Terminal	: Brass With Gold Plated
△ Tape	: KAPTON

# SOLDERING PROCESS

## △CLEANING:

1. Only Tape sealed types apply to wash process.
2. Do not remove the tape before wash process.
3. After soldering process, do not continue the wash process immediately. Please wait for at least 3 minutes.
4. Apply alcoholic solvents as cleaning agent do not use other solvents or water.
5. Ultrasonic cleaning is not recommended.
6. The cleaning process per stage is max. 1 minute and the whole cleaning time are not to exceed 3 minutes.
7. Do not impose any external force on switch while washing.

△ Any flux enters the switch may fail the conductivity.

△Reflow Temperature Profile: (reference)

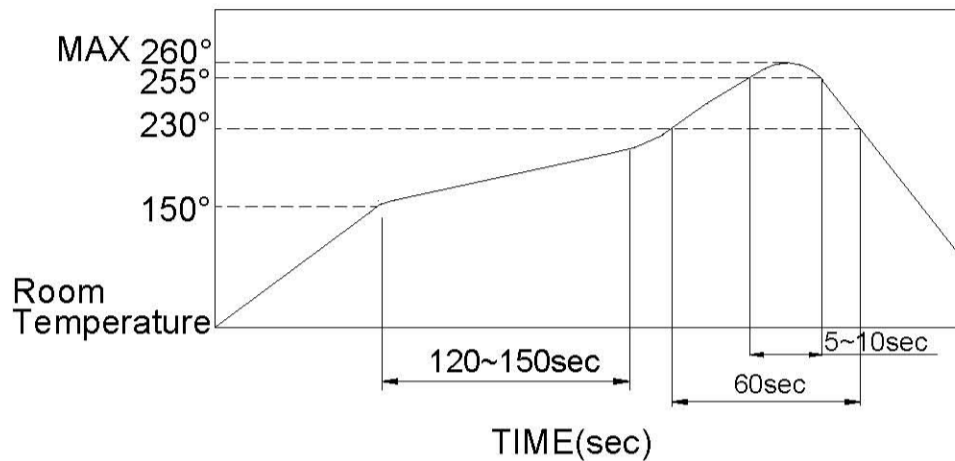

# PACKING

## NHDS CARRIER

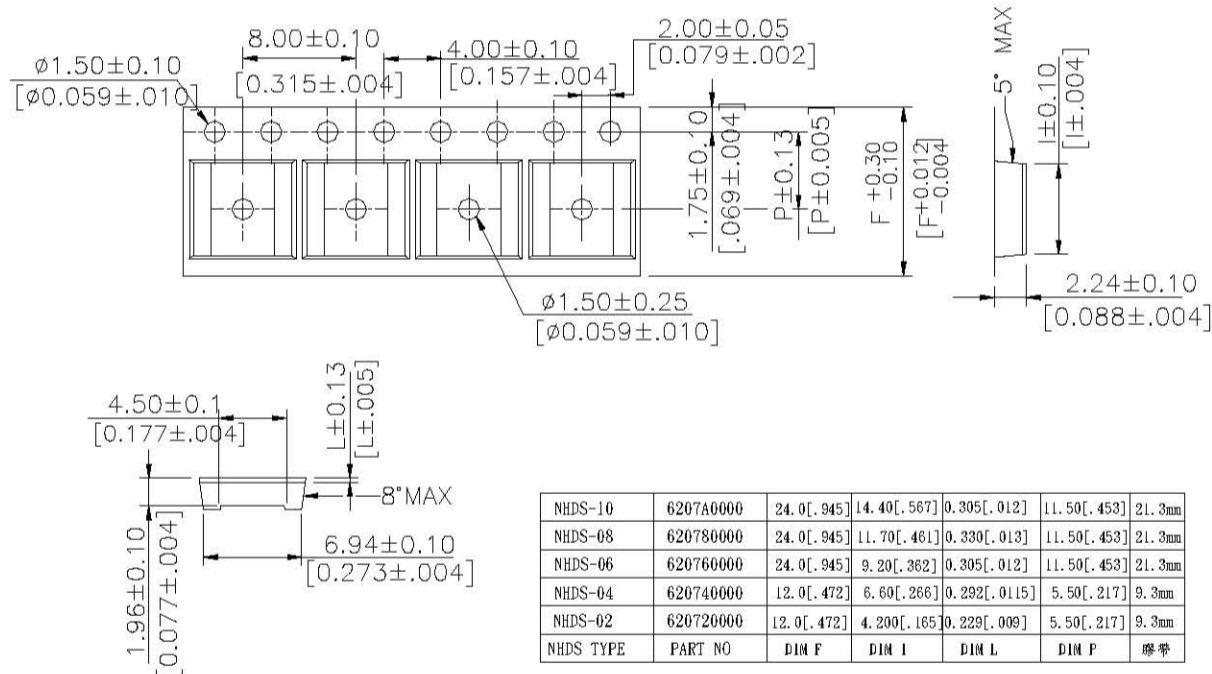

\*\*GENERAL TOLERANCES MAX:±0.1mm.\*\*

## FHDS CARRIER

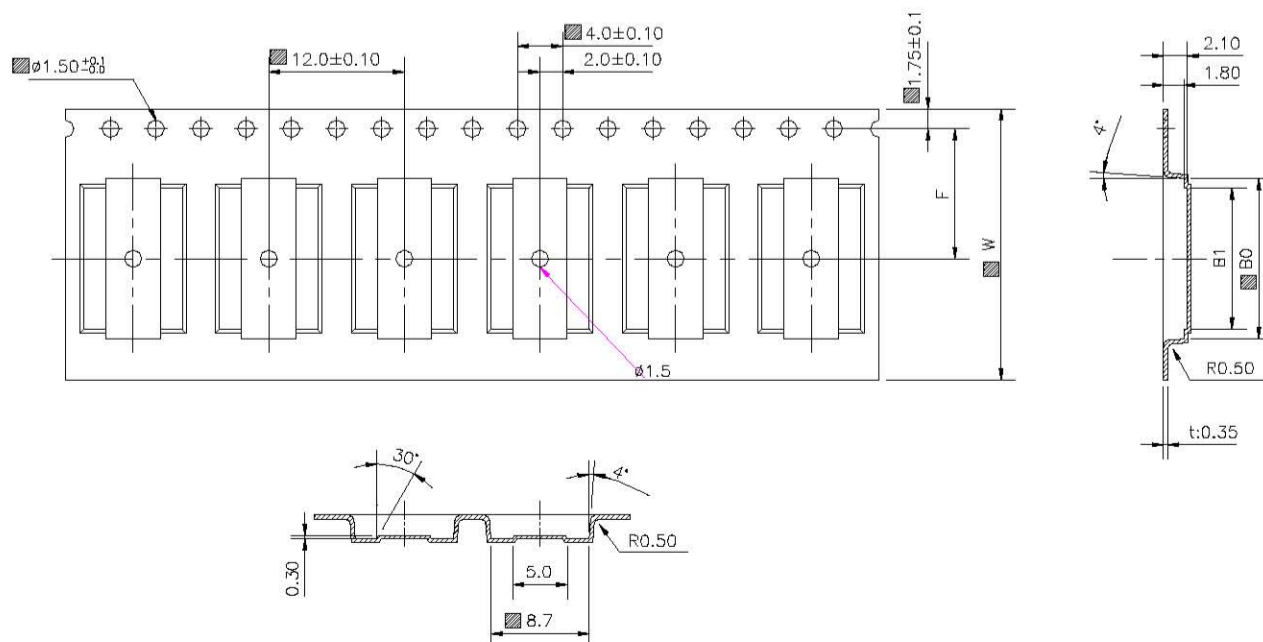

FHDS-10	6217A0000	24.00±0.3	11.00±0.1	14.23	12.50
FHDS-08	621780000			11.65 <sup>+0.20</sup> <sub>-0.20</sub>	9.96
FHDS-06	621760000			9.15 <sup>+0.20</sup> <sub>-0.20</sub>	7.42
FHDS-04	621740000			6.61	4.88
FHDS-02	621720000			4.07	2.34
PART NAME	PART NO	DIM W	DIM F	DIM B0	DIM B1

\*\*GENERAL TOLERANCES MAX:±0.1mm.\*\*

**NHDS TUBE**

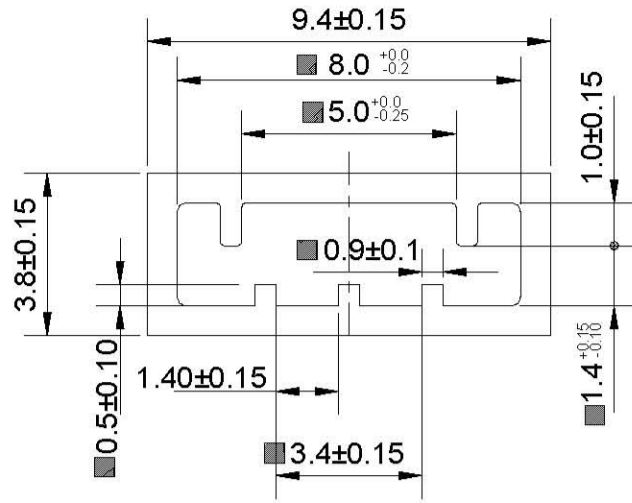

**\*\*GENERAL TOLERANCES MAX:±0.20mm.\*\***

**FHDS TUBE**

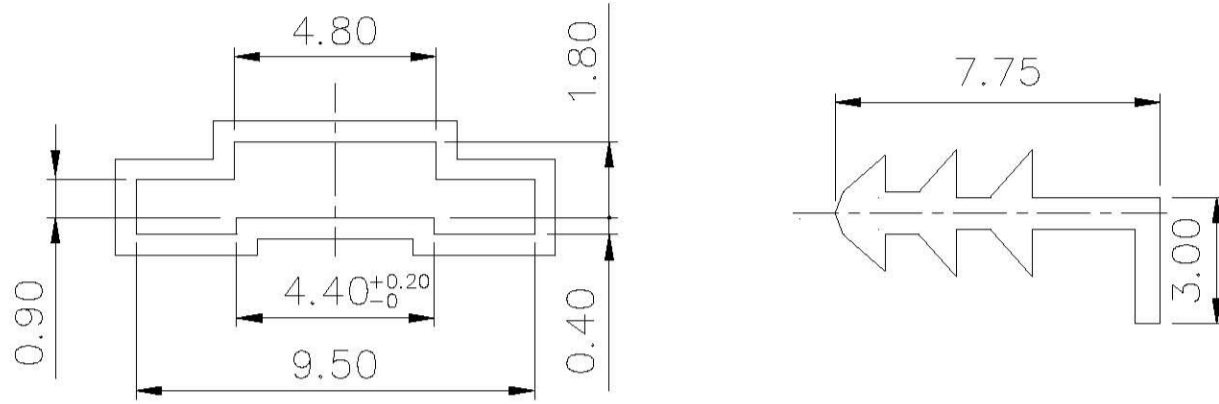

**\*\*GENERAL TOLERANCES MAX:±0.20mm.\*\***

Part Number	Number Per Tube	Number Per Reel
NHDS-02	125	4000
NHDS-04	75	4000
NHDS-06	54	4000
NHDS-08	40	4000
NHDS-10	33	4000
FHDS-02	125	2500
FHDS-04	75	2500
FHDS-06	54	2500
FHDS-08	40	2500
FHDS-10	33	2500